



1907 Woodland Ave.
Coffeyville, KS 67337
Phone: (620) 251-9100
Fax: (620) 251-2622

BIGBOY BRACKETS
2007-2010 Two Door Models & 2007-2015 Four Door Models
DRIVER'S SIDE for RIGHT HAND DRIVE JEEPS
JBBJK-RHD

WARNING

*FOR YOUR SAFETY
YOU MUST FOLLOW
THESE
INSTRUCTIONS*

1. To avoid serious or fatal injury on vehicles equipped with airbags, disable the Supplemental Restrain System (SRS) before attempting any steering wheel, steering column, airbag, seat belt tensioner, impact sensor or instrument panel component diagnosis or service.

Remove the key from the ignition.
Disconnect and isolate the battery negative (ground) cable, then wait 30 minutes for the system capacitor to discharge before performing further diagnosis or service. This is the only sure way to disable the SRS. Failure to take the proper precautions could result in accidental airbag deployment.

2. Disconnect the snap wire connectors between the floor and the seat.

3. Remove and save the (4) bolts holding the seat frame to the floor. These will be reused when installing the new brackets. Remove the seat from the vehicle.

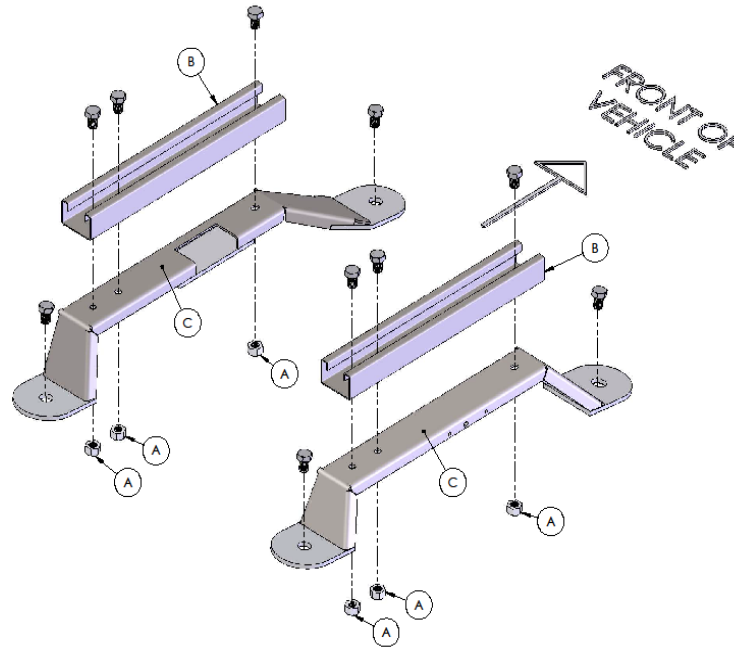

4. Remove the (3) 13mm flange nuts (A) from each side of the seat that hold the slider frames (B) to the original floor brackets.

5. Install the big boy brackets (C) to the slider frames (B) reusing the 13mm flange nuts (A) as shown in the installation drawing.

6. Reinstall the seat in the vehicle and reconnect the snap wire connector between the floor and the seat.

Now that the installation is complete, you should have approximately 2" more leg room for the driver's seat.

Liability Release

The purchaser of this product agrees that the manufacturer of this product has no responsibility or liability for errors in installation and/or resulting injury and/or accidents resulting from or associated with use and/or installation of this product.

Purchaser agrees to release manufacturer from any and all liability for personal injuries including death and property losses or damage occasioned by, or in connection with any activity or accommodations for use and/or installation of this product, either professionally installed or self installed.

Purchaser furthermore agrees to hold harmless and indemnify said manufacturer organization(s) its directors, employees and agents, for any liability sustained by use and/or modifications of product or vehicle, including claims for damages, losses, injuries, and expenses arising out of or resulting from use of product.